

TYPICAL INSTALLATION
FOR ENGINE COMPARTMENT

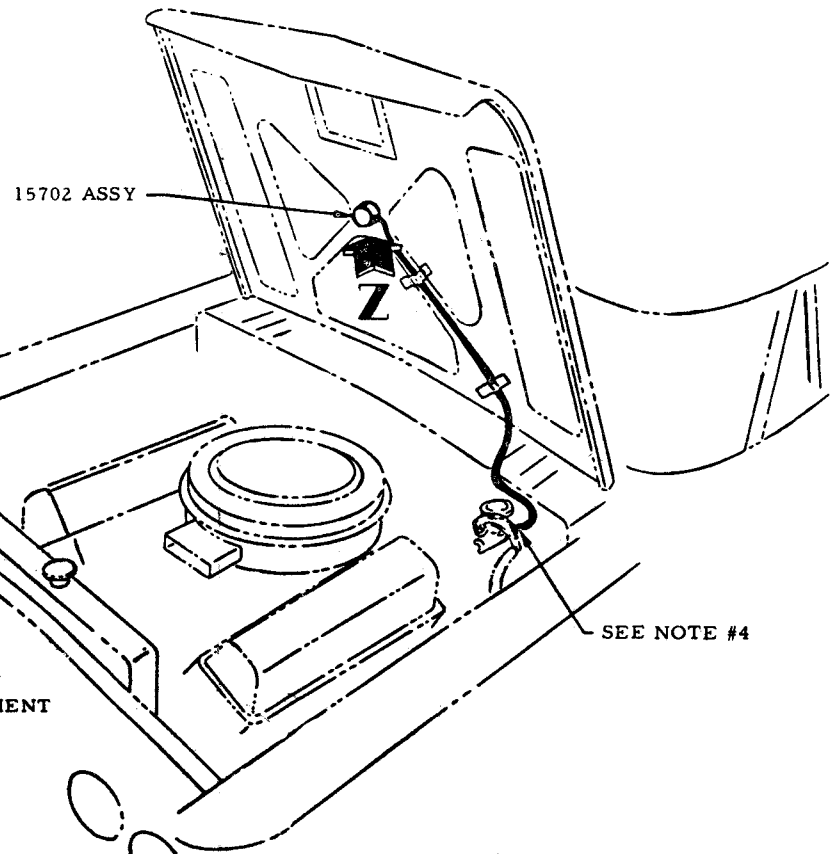

INSTALLATION INSTRUCTIONS

1. SELECT A POSITION FOR THE LAMP ASSY ON THE UNDER-SIDE OF HOOD OR DECK LID THAT WILL NOT CAUSE INTERFERENCE WHEN EITHER IS CLOSED.
2. IF THE LAMP ASSY CANNOT BE INSTALLED OVER A SLOT OR HOLE FOR WIRE ROUTING, NOTCH THE SIDE OF THE LAMP ASSY WITH A FILE AS SHOWN -- VIEW Y.
3. MOUNT LAMP ASSY WITH THE LIGHT BULB IN THE LOWEST POSITION AND TIGHTEN SCREWS. TAPE OR CLIP WIRE SECURELY WHILE ROUTING -- ALLOW WIRE FOR HINGING.
4. CONNECT THE WIRE TO THE TAIL LIGHT LEAD (TRUNK) BY SPLICING. TAPE SECURELY.

UNDER THE HOOD, CONNECT THE WIRE TO THE STOPLIGHT "HOT" LEAD OR TO ANY OTHER EXISTING "HOT" WIRE. SPLICE AND TAPE SECURELY.

5. OPEN AND CLOSE THE HOOD OR DECK LID SEVERAL TIMES TO CHECK THE OPERATION OF THE SELF-CONTAINED MERCURY SWITCH.

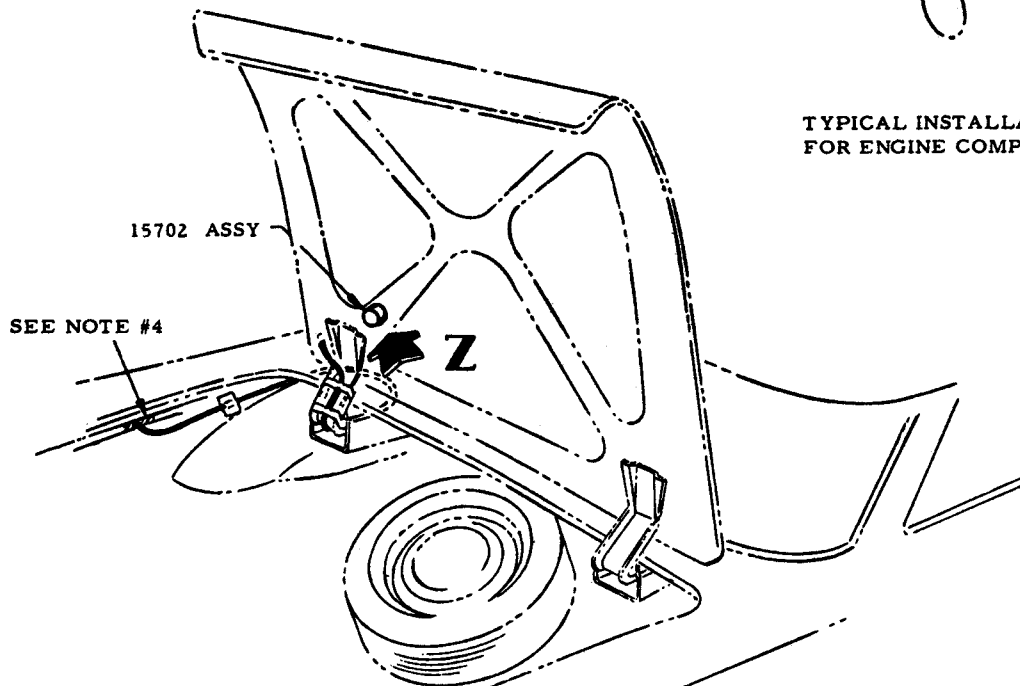

TYPICAL INSTALLATION
FOR TRUNK COMPARTMENT

I. S. 867
INSTALLATION-LAMP ASSY-ENGINE
COMPARTMENT(TRUNK COMPARTMENT)

